



RINGO
DRILLING I, L.P.

Table of Contents

Company Bio	3
Contact Information.....	4
Rig #1	6
Rig #2	7
Rig #3	8
Rig #4	9
Rig #5	10
Rig #6	11
Rig #7	12
Rig #8	13
Rig #9	14
Rig #12	15
Rig #16	16
Rig #17	17
Rig #18	18
Rig #19	19
Rig #20	20
Rig #21	21
Rig #22	22
Rig Footprints.....	23
Ringo Trucking, LLC	24

Ringo Drilling I, L.P.

Ringo Drilling I, L.P. is a full service drilling company headquartered in Tye, Texas with corporate offices located in Dallas.

The company prides itself on a reputation for excellent, dependable, quality work; covering vertical, horizontal, fluid, and air drilling.

Ringo has its own full service trucking fleet (with yards in Tye and San Angelo), employs in-house mechanics and welders all focused to minimize job site down time. Ringo has the capability to refurbish and manufacture rigs.

Ringo considers HSE (Health, Safety & Environment) a top priority. Ringo has pre-employment, random and post accident drug testing program. They also have a training program for new hires and provide substantial incentives to employees for safe working conditions and a drug free work place. Policies are designed to encourage the responsible development of energy resources in a manner that is protective of human health and safety, and the environment.

Contact Information

Home Office

(325) 695-5600
Fax (325) 695-5639
104 Spinks Road
Tye, Texas 79563

Corporate Office

(972) 458-7468
Fax (972)386-4753
12900 Preston Rd, Ste 730
Dallas, Texas 75230

www.ringodrilling.com



Murl Richardson

Chief Executive Officer
murl@ringodrilling.com
Fort Worth, Texas

Bill Middleton

General Partner
middleton@ringodrilling.com
Dallas, Texas

Bill Martin

Chief Operations Officer
bill@ringodrilling.com
Tye, Texas

Paul Drennan

President
paul@ringodrilling.com
San Angelo, Texas

Jeff Kovach

Chief Financial Officer
kovach@ringodrilling.com
Dallas, Texas

Steve Gibson

Contract Manager
steve@ringodrilling.com
Tye, Texas

Ringo's Fleet



RINGO
Drilling I, L.P.

Rig 1

RINGO
DRILLING I, L.P.

Drawworks: National T-32 single drum, 400 HP, Foster catheads, p/b CAT 3406.

Derrick: Al Hicks 100'H x 11'6"W 300,000# static hook load Cantilever, pin-type, crown w/ (4) sheaves.

Substructure: Al Hicks 10'H x 28'W x 38'L Box type.

Block/Hook: National Ideal 140 ton block & hook assembly w/ (4) 30" sheaves (2) 2 3/4" x 84" elevator bells.

Swivel: Emsco LB-140 5 1/4" x 40'L kelly w/ mousehole & shuck. Varco type kelly drive bushing w/ square drive.

Rotary Table: Gardner-Denver 20 1/2" x 44" w/ split master bushing.

BOP: Hydril 10" Reagan Bladder

Closing Unit: Koomey 3-Station w/ air-operated hydraulic pump, 14"W x 36"H x 48"L hydraulic tank (Mud Cross).

Mud Pump #1: Skytop Brewster B-550, 400HP

Mud Pump #2: Skytop Brewster B-550, 400HP

Mixing Tank: 6'H x 7'W x 8'L

Steel Pits: (Pit #1) 5'H x 8'W x 40'L mud suction tank w/ (3) compartments. (Pit #2) 5'H x 8'W x 40'L mud shaker tank w/ (3) compartments, & single vibrating shale shaker .

Generator House: Lima 100 KW AC generator, p/b CAT 3304 mounted on skid of 6000 gal. Diesel Tank w/ Quincy 325 air compressor & 4-compartment lubester.

Fuel Tank: (6000 gal.)



Water Tank: (11,000 gal.) 8'W x 8'H x 23'L w/ 11' L changing house.

Dog House: 8'W x 20'L top w/ round top

Pipe Baskets: (4) 36"H x 7'W x 36'L

Pipe Racks: (6) 42"H x 28'L Triangular

Drill Pipe: 4 1/2" XO

Drill Collars: (20) 6" (2) 8"

House Trailer: Terry 8'W x 23'L tandem axle

(Footprint is on page 23)

Rig 2

RINGO
DRILLING I, L.P.

Drawworks: Skytop Brewster N-42 single drum 650 HP, Foster catheads, p/b (2) CAT C-15 450HP.

Derrick: Lee C. Moore 112'H cantilever, pin-type, crown w/ (4) sheaves.

Substructure: Al Hicks 12'H x 20'W x 42'L

Block: McKissick 150 ton w/ (4) sheaves.

Hook: Web Wilson (2) 2 3/4" x 96" Elevator Bells.

Swivel: Continental Emsco LB-200 5 1/4" x 40'L Kelly w/ mousehole & shuck Varco kelly drive bushing w/ square drive.

Rotary Table: Gardner-Denver 17 1/2" x 44" rotary table w/ split master bushing.

BOP: Hydril 11" 3000 GK-10-900

Closing Unit: Valvcon 5-station w/ triplex hydraulic, pump, air-operated hydraulic pump, 80 gal. spherical, accumulator. Mud cross.

Mud Pump #1: Continental Emsco DB-550 550 HP p/b CAT C-15.

Mud Pump #2: Continental Emsco DB-550 550 HP p/b CAT 3406.

Mixing Tank: 5'H x 8'W x 8'L

Steel Pits: (Pit #1) 4'H x 12'W x 36'L 385-Barrel mud suction tank w/ (3) compartments (Pit #2) 4'H x 12'W x 36'L 385-Barrel mud shaker tank w/ (3) compartments, vibrating shale shaker.

Generator House: CAT SR-4 113KW AC Generator, p/b CAT 3304, mounted on skid extension of 8'Dia x 24'L fuel tank.

Air Compressor: Quincy 325L (stby)



Fuel Tank: (9000 gal.) 8'Dia x 24'L w/ 3-compartment lubester, day tank.

Water Tanks: (Tank #1) (13,500 gal.) 10'W x 6'H x 30'L, 8'L change and parts house (Tank #2) (21,000 gal.) 10'6"Dia x 32'L 500-Bbl.

Dog House: 8'W x 20'L Top Doghouse w/ round top.

Pipe Baskets: (5) 36"H x 7'W x 36'L

Pipe Racks: (6) 42"H x 28'L Triangular

Drill Pipe: 4 1/2" XO

Drill Collars: (20) 6" (2) 8"

House Trailer: Fleetwood Prowler

(Footprint is on page 23)

Rig 3

RINGO
DRILLING I, L.P.

Drawworks: BDW 450-T Single Drum 450 HP, Foster catheads, p/b (2) CAT 3306.

Derrick: Al Hicks 100'H x 11' 6"W Cantilever, pin-type, crown w/ (4) sheaves.

Substructure: Al Hicks 10'H x 28'W x 38'L

Block: McKissick 150 ton

Hook: BJ Unimatic 6150 w/ (4) sheaves (2) 2 3/4" x 84" Elevator Bells.

Swivel: TSM 150 40'L Square Kelly w/ Mouse-hole & Shuck. Varco Kelly Drive Bushing w/ square drive.

Rotary Table: Continental Emsco T-1750 17 1/2" x 44" w/ split master bushing.

BOP: Shaffer Type E 10" BOP w/ 4 1/2" pipe & blind rams.

Closing Unit: Koomey 2-Station w/ air-operated hydraulic pump, hydraulic tank & Mud Cross.

Mud Pump #1: Emsco DB-550 p/b CAT 353

Mud Pump #2: Oilwell 214-P 350 HP p/b CAT 3406

Mixing Tank: 5'H x 8'W x 8'L

Steel Pits: (Pit #1) 4'H x 12'W x 38'L Mud Suction Tank w/ (3) compartments (Pit #2) 4'H x 12'W x 38'L Mud Shaker Tank w/ (3) compartments, vibrating shale shaker.

Generator House: Magna Plus synchronous AC generator p/b Perkins w/ Quincy 325 air compressor.

Fuel Tank: (6000 gal.) 7'Dia x 22'L Fuel Tank w/ 4-compartment lubester.



Water Tank: (18,000 gal.) 8'W x 8'H x 38'L

Dog House: 8'W x 20'L Top Doghouse w/ round top

Bottom Dog House: 7'W x 21'L Changing & Parts House w/ round top

Pipe Baskets: (4) 36"H x 7'W x 36'L

Pipe Racks: (6) 42"H x 28'L Triangular

Drill Pipe: 4 1/2" XO

Drill Collars: (18) 6" (2) 8"

House Trailer: '99 Jay

(Footprint is on page 23)

Rig 4

RINGO
DRILLING I, L.P.

Drawworks: Shaffer SOS 600S 600 HP, makeup & breakout catheads, p/b (2) CAT 3306.

Derrick: Al Hicks 100'H x 11'6"W Cantilever, pin-type, crown block w/ (4) sheaves.

Substructure: Ringo 10'H x 18'W x 38'L

Block: Arctic

Hook: BJ T-150 w/ (4) sheaves, (2) 2 3/4" x 96" Elevator Bells.

Swivel: Continental Emsco LB-140 40' Square Kelly w/ Mousehole & Shuck, Varco Kelly Drive Bushing w/ square drive.

Rotary Table: Continental Emsco 17 1/2" x 44" w/ split master bushing.

BOP: Shaffer Type E 10" w/ 4 1/2" pipe & blind rams.

Closing Unit: Hydril 3-Station w/ (2) air-operated hydraulic pumps, 14" x 36" x 8'L hydraulic tank, 80-gal. Spherical accumulator 5000 psi Choke Manifold.

Mud Pump #1: Continental Emsco DB-550 p/b CAT D-353

Mud Pump #2: Oilwell 218-P 500 HP p/b CAT D-353

Mixing Tank: 5'H x 8'W x 8'L

Steel Pits: (Pit #1) 4'H x 12'W x 38'L Mud Suction Tank w/ (3) compartments (Pit #2) 4'H x 12'W x 38'L Mud Shaker Tank w/ (3) compartments, vibrating shale shaker.

Generator House: CAT S-4 113 KW AC Generator p/b CAT 3304, mounted on skid extension of 7'Dia x 23'L Fuel Tank w/ Quincy 325 air compressor.



Fuel Tank: (6500 gal.) 7'Dia x 23'L w/ (4) compartment lubester.

Water Tanks: (Tank #1) (21,000 gal.) 10'6"DIA x 32'L 500bbl (Tank #2) (13,000 gal.) 8'W x 8'H x 28'L & 10'L changing house.

Dog House: 8'W x 20'L Top Doghouse w/ round top

Pipe Baskets: (4) 36"H x 7'W x 36'L

Pipe Racks: (6) 42"H x 28'L Triangular

Drill Pipe: 4 1/2" XO

Drill Collars: (18) 6" collars (2) 8" collars

House Trailer: '84 FTWD

(Footprint is on page 23)

Rig 5

RINGO
DRILLING I, L.P.

Drawworks: Shaffer SOS 6000S Single Drum, Foster catheads, p/b (2) CAT 3306.

Derrick: Al Hicks 100'H x 11' 6"W Cantilever, pin-type, crown block w/ (4) sheaves.

Substructure: Al Hicks 10'H x 28'W x 38'L Box-Type Substructure w/ rotary beams, v-door, stairs, & safety rails.

Block/Hook: Web Wilson 150-ton Block/Hook w/ (2) 2 3/4" x 96" Elevator Bells.

Swivel: TSM 150 w/ 40'L Square Kelly w/ Mousehole & Shuck, Baash-Ross-Type Kelly Drive Bushing.

Rotary Table: Emsco T-2050 20 1/2" x 44" w/ split master bushing.

BOP: Shaffer Type E 3000 10"ID x 20"H

Closing Unit: Payne 2-Station w/ air operated hydraulic pump, hydraulic tank. 5000 psi Choke Manifold.

Mud Pump #1: Continental Emsco DB-550 p/b CAT C-15

Mud Pump #2: Oilwell 214-P 350 HP p/b CAT 3406

Mixing Tank: 6'H x 7'W x 8'L w/ v-bottom, mud hopper, and skidded.

Steel Pits: (Pit #1) 4'H x 12'W x 38'L Mud Suction Tank w/ (2) Compartments (Pit #2) 4'H x 12'W x 38'L Mud Shaker Tank w/ (3) Compartments, vibrating shale shaker.

Generator House: 113 KW AC Generator p/b CAT 3304, w/ Quincy 355 air compressor, & 4-compartment lubester



Fuel Tank: (6000 gal.) Mounted on the generator house

Water Tanks: (Tank #1) (21,000 gal.) 10'6"Dia x 32'L 500-Bbl, skidded w/ (1) 2" butterfly valve & (1) 4" butterfly valve. (Tank #2) (14,000 gal.) 7'9"W x 8'H x 30'L w/ 12ft. bottom doghouse.

Dog House: 8'W x 20'L round top, Top Dog-house

Pipe Baskets: (4) 36"H x 7'W x 36'L

Pipe Racks: 3 Sets (6) 3'T x 4'W x 26 1/2'L Triangular

Drill Pipe: 4 1/2" XO

Drill Collars: (20) 6" (2) 8"

House Trailer: Road Ranger Monterey- 30WT

(Footprint is on page 23)

Rig 6

RINGO
DRILLING I, L.P.

Drawworks: BDW 450T Single Drum, Foster Catheads, p/b (2) CAT 3306

Derrick: Leco 100'H x 11' 6"W Cantilever, pin-type, crown w/ (4) sheaves.

Substructure: Leco 9'H x 18'W x 38'L

Block: McKissick

Hook: BJ Unimatic 6150 (2) 2 3/4" x 96" Elevator Bells

Swivel: Continental Emsco LB-200 40'L Kelly w/ Mousehole & Shuck, Varco Kelly Drive Bushing w/ square drive.

Rotary Table: Ideco 175F 17 1/2" x 44"

BOP: Shaffer Type E 10" w/ 4 1/2" pipe & blind rams.

Closing Unit: Hydril 4-Station w/ air-operated hydraulic pump hydraulic tank, (80 gal) spherical accumulator

Mud Pump #1: Oilwell 214-P 350 HP p/b CAT C-15

Mud Pump #2: Continental Emsco D-375 p/b CAT 3406

Mixing Tank: 6'H x 7'W x 8'L

Steel Pits: (Pit #1) 4'H x 12'W x 38'L Mud Suction Tank w/ (2) compartments (Pit #2) 4'H x 12'W x 38'L Mud Shaker Tank w/ (3) compartments, & Mud Smith vibrating shale shaker.

Generator House: 113 KW AC Generator, p/b CAT 3304 engine, mounted on skid extension of 4000 gal. Fuel Tank w/ Quincy 325 air compressor, 3-compartment lubester, day tank

Fuel Tank: (4000 gal.) mounted on generator house.



Water Tanks: (Tank #1) (21,000 gal.) 10' 6"Dia x 32'L 500-Bbl (Tank #2) (12,500) 8'W x 8'H x 26'L

Dog House: 8'W x 20'L Top Doghouse w/ round top

Pipe Baskets: (4) 36"H x 7'W x 36'L

Pipe Racks: (6) 42"H x 28'L Triangular

Drill Pipe: 4 1/2" XO

Drill Collars: (21) 6" collars

House Trailer: Wilderness 1994

(Footprint is on page 23)

Rig 7

RINGO
DRILLING I, L.P.

Drawworks: TSM 850 Drum 18" x 37" p/b
John Deere 6135L

Derrick: Lee C. Moore

Double Configuration 112'

Triple Configuration 131'

Substructure: Ringo Box Type 10'T x 18'6W
x 40'L

Block: McKissick 150 ton

Hook: BJ

Swivel: LB 200

Rotary Table: Emsco 17 1/2"

BOP: HyDril 10" 900 #3000

Closing Unit: Payne 3-station 20 gal

Mud Pump #1: Emsco D-550

Motor: CAT C-15

Mud Pump #2: Ideal C-250

Motor: CAT 3406

Steel Pits: (2) 4'H x 12'H x 38'L 3 compart-
ments w/ mixing tank

Shale Shaker: Mud Smith Vibrating

Generator House: (2) CAT SR4 113 KW gen-
erators p/b CAT 3304 & (1) Quincy 325LVD-
106 air compressor

Fuel Tank: (17,000 gal.) 32'L x 7'H x 10'W w/
parts house

Water Tank: (21,000 gal.) 10'Dia x 32'L
500bbl



Dog House: 25'L x 7'6"W

Bottom Doghouse: 28'L x 7' 6"W

Pipe Baskets: (4) 35'L x 7' 6"W x 3'T

Pipe Racks: (6) 28'L x 42"T x 42"W (made
from pipe)

Drill Pipe: 4 1/2" XO

Drill Collars: (18) 6 1/4" (2) 8" (1) bottom hole

House Trailer: Nu-Wa Hitchhiker II

(Footprint is on page 23)

Rig 8

RINGO
DRILLING I, L.P.

Drawworks: Mid-Continent U-34B Single Drum, Foster catheads, p/b CAT C-15 engine

Derrick: Al Hicks 100'H Cantilever, pin type, crown block w/ (4) sheaves.

Substructure: Ringo 10'H x 20'W x 40'L

Block: McKissick

Hook: Web Wilson w/ (4) sheaves, (2) 2 3/4" x 84" Elevator Bells.

Swivel: TSM 150 40'L Kelly w/ Mousehole & Shuck Varco Kelly Drive Bushing w/ square drive.

Rotary Table: Continental Emsco T-1750 17 1/2" x 44" w/ split master bushing.

BOP: Regan 10" Annular

Closing Unit: 1-Station Closing Unit w/ Payne air-operated, (2) accumulators

Mud Pump #1: Continental Emsco 375 p/b CAT C-15

Mud Pump #2: Continental Emsco 375 p/b CAT 3406

Mixing Tank: 6'H x 5'W x 7'L eye wash station & skidded.

Shale Shaker: p/b electric motor

Generator House: CAT SR-4 Gen. p/b CAT 3304 mounted on the fuel tank.

Air Compressor: Quincy 324 (stby) 5HP electric

Fuel Tank: (7000 gal.) 8'Dia x 18' 6"L, 4-compartment lubester.

Water Tank: (24,000' gal.) 8'W x 10'H x 40'L



Dog House: 8'W x 36'L Top Doghouse/ Changing House w/ round top

Pipe Baskets: (3) 36"H x 7'W x 34'L

Pipe Racks: (4) 42"H x 28'L Triangular

Drill Pipe: 4 1/2" XO

Drill Collars: (20) 6" (2) 8"

House Trailer: Jayco 250 FS Eagle 1996

(Footprint is on page 23)

Rig 9

RINGO
DRILLING I, L.P.

Drawworks: National T-32 Single Drum 400HP, makeup & breakout catheads, p/b CAT C-9 engines.

Derrick: Lee C. Moore 105'H x 13'W Cantilever, pin-type, crown block, w/ (5) sheaves.

Substructure: Al Hicks 10'H x 23'W x 45'L

Block: McKissick

Hook: BJ 6150 150-ton w/ (4) 30" sheaves, (2) 3" x 96" Elevator Bells.

Swivel: Emsco LB-140 40'L Kelly w/ Mouse-hole & Shuck, Varco Kelly Drive Bushing w/ Square Drive.

Rotary Table: Oilwell 17 1/2" x 44" w/ Split Master Bushing.

BOP: Shaffer Type E 11" w/ 4 1/2" pipe & blinds.

Closing Unit: Payne 2-Station w/ air operated hydraulic pump, hydraulic tank.

Mud Pump #1: Emsco DB-550 p/b CAT C-15

Mud Pump #2: Emsco DB-550 p/b CAT 3406

Mixing Tank: 5'6"H x 7'W x 8'L

Steel Pits: (Pit #1) 4'H x 12'W x 36'L Mud Suction Tank w/ (2) compartments (Pit #2) 4'H x 12'W x 36'L Mud Shaker Tank w/ (3) compartments, single vibrating shale shaker.

Generator House: CAT SR-4 113KW AC generator p/b CAT 3304.

Air Compressor: 2006 Manchester (parts house)

Fuel Tank: (4500 gal.) 7'Dia x 16'L & 3-compartment lubester.



Water Tank: (19,000 gal.) 8'W x 8'H x 40'L

Dog House: 7'6"W x 24'L Top Doghouse w/ round top.

Dog/Parts House: 7'6"W x 34'L Parts House, 06' Manchester air compressor .

Pipe Baskets: (4) 3'H x 7 1/2'W x 36' 10"L

Pipe Racks: (6) 3' 8"H x 4'W x 28'L Triangular

Drill Pipe: 4 1/2" XO

Drill Collars: (2) 8" Collars (18) 6" Collars

House Trailer: 1993 FTWD

(Footprint is on page 23)

Rig 12

RINGO
DRILLING I, L.P.

Drawworks: Shaffer SOS 6000 Twin engine compound (UHT500) p/b (2) CAT 3306.

Derrick: Al Hicks 101'L x 12' 3"W

Substructure: 6'H x 20'W x 34' 4"L Box type. 25'L x 4'6"W x 42"T (2) made from pipe.

Block: Arctic 150 BJ Unimatic 6150

Hook: BJ Hughes C150

Swivel: Emsco LB-140 Square Kelly 4 1/4" x 2 1/4" x 40'L

Rotary Table: Gardner Denver 17 1/2"

BOP: Dorland 10" 3000

Closing Unit: Koomey

Mud Pump #1: Emsco 214P p/b CAT 3406C

Mud Pump #2: Emsco D-375 p/b Volvo-Penta 1241VE

Mixing Tank: 30 BBL

Shale Shaker: Barrel-Type

Generator House: Magna Plus 100KW generator p/b Perkins 1424

Air Compressors: (2) Quincy 325

Fuel Tank: (5750 gal.) 7'Dia x 20'L, 30'L x 8'W

Water Tank: (14,000 gal.) 32'L x 10'W x 6'H w/ 12'5" x 10'W/ bottom doghouse.

Dog House: 20'L x 8'W

Pipe Baskets: (4) 35'L x 7'6"W x 3'T

Pipe Racks: (6) 28'L x 42"T x 42"W

Drill Pipe: 4 1/2" XO

Drill Collars: (20) 6" Collars



House Trailer: Damon 27H Hornet TT

(Footprint is on page 23)

Rig 16

RINGO
DRILLING I, L.P.

Drawworks: Emsco GB 500, Catheads – Kelco, model #16LB, p/b (2) CAT C18.

Derrick: Lee C. Moore 131', 8 line crown and block 1 1/8.

Substructure: Ringo 21.6' W x 50' L x 12' H Split type w/boosters for (1) piece haul.

Block/Hook: McKissick 250 ton

Swivel: Emsco LB-200 Kelly 5 ¼ hex w/ 6 5/8 box, 4 ½ XH pin, 40' long, w/Varco 5 ¼ hex bushing.

Rotary Table: Emsco 20 1/2"

BOP: Shaffer C1117

Closing Unit: Koomey

Mud Pump #1: Emsco D500 p/b CAT 353

Mud Pump #2: Emsco D500 p/b Detroit 12v 71

Steel Pits: (2) pit system, 600 bbl w/ shale shaker

Generator House: 7.10 W x 8 H x 30 L (2) 155 KW generator 240 volts 2/220 p/b CAT 3306, & Gardner Denver 240 air compressor.

Fuel Tank: (12,000 gal.) 7.10 x 40', 1" air diaphragm fuel pump.

Water Tank: (17,000 gal.) 7.10 W x 8 H x 40L

Dog House: 7.6 x 32 x 7

Dog House: 7.10 W x 8 H x 40 L (change house)

Pipe Baskets: (4) 35'L x 7' 6"W x 3'T

Pipe Racks: (6) 28'L x 42"T x 42"W (made from pipe)



Drill Pipe: 4 1/2" XO

Drill Collars: (20) 6 1/2" (1) Bottom hole (2) 8"

House Trailer: Skyline Aljo-1902

(Footprint is on page 23)

Rig 17

RINGO
DRILLING I, L.P.

Drawworks: 700HP Gardner Denver 500 single drum mechanical, Foster make up & break out cat heads, p/b (2) Detroit 60 series diesel engines

Derrick: Lee C. Moore 127' cantilever

Substructure: Lee C. Moore, 15' floor height, w/ 12' clear height under rotary beams

Block/Hook: National/Ideal 435-G175 (175 ton)

Swivel: Mud King 25MB (250 ton)

Rotary Table: Oilwell 27 1/2" w/ split master bushing

BOP: Shaffer LWS 11" 5000# Double Ram w/ 4 1/2" pipe and blind rams, and Shaffer 11" 5000# annular

Closing Unit: Koomey 5 station, 160 gallon

Mud Pump #1: EMSCO RS-1000 triplex, p/b CAT D-398

Mud Pump #2: EMSCO DA-500 p/b CAT D-353

Steel Pits: (2) 45'L x 10'W x 7'H

Generator House: 10' x 51' utility house w/ parts storage room, change room w/ lockers, electric distribution center w/ (1) 30hp Sullivan Palatek air compressor, (2) 350KW gen. set p/b Detroit Diesel 60 series.

Fuel Tank: (5,000 gal.) 12'L x 7'W x 8'H

Water Tank: (30,000 gal.)

Dog House: 50'L x 10'W x 8'H

Drill Pipe: 4 1/2" XO

Drill Collars: 18

House Trailer: Toolpusher's quarters, skidded



(Footprint is on page 23)

Rig 18

RINGO
DRILLING I, L.P.

Drawworks: (1000hp) Mid-Continent U-20 1000HP, single drum mechanical, 1 1/4" lebus grooving, Kennecor Hydraulic make up & break out catheads, p/b (2) CAT C-18 rated @ 630hp

Derrick: Lee C. Moore 131' cantilever

Substructure: Lee C. Moore, 16' floor height, w/ 14' clear height under rotary beams

Block/Hook: EMSCO (200 ton)

Swivel: 225 ton

Rotary Table: Petro 20 1/2" square drive w/ split master bushing

BOP: Cameron 11" 5000# Double Ram w/ 4 1/2" pipe and blind rams, and Hydril 11" 5000# annular

Closing Unit: Koomey 8 station, 160 gallon

Mud Pump #1: Bomco 1000hp triplex, p/b CAT D-398

Mud Pump #2: Bomco 1000hp triplex, p/b CAT D-398

Steel Pits: (2 tank) 800 Bbl mud system

Generator House: 10' x 51' utility house w/ parts storage room, change room w/ lockers, electric distribution center w/ (1) 30hp Sullivan Palatek air compressor, (1) 400KW gen. set p/b Detroit Diesel 60 series (1) 350KW CAT C-15.

Fuel Tank: (10,500 gal.)

Water Tank: (21,000 gal.)

Dog House: 50'L x 10'W x 8'H

Drill Pipe: 4 1/2" XO

Drill Collars: (21) 6" (3) 8"



House Trailer: Toolpusher's quarters, skidded

(Footprint is on page 23)

Rig 19

RINGO
DRILLING I. L.P.

Drawworks: (1260HP) National 50A single drum mechanical, 1 1/8" lebus grooving, Foster make up & break out catheads, p/b (2) CAT C-18 rated @ 630hp

Derrick: Lee C. Moore 127' cantilever

Substructure: Lee C. Moore, 14' floor height, w/ 11' clear height under rotary beams

Block/Hook: EMSCO (200 ton)

Swivel: Gray (200 ton)

Rotary Table: Ideco 23 1/2" square drive w/ split master bushing

BOP: Shaffer LWS 11" 3000# Double Ram w/ 4 1/2" pipe and blind rams, and Hydril 11" 3000# annular

Closing Unit: Koomey 5 station, 160 gallon

Mud Pump #1: RS 1000hp triplex, p/b CAT 3508

Mud Pump #2: Bomco 1000hp triplex, p/b CAT 3508

Steel Pits: (2 tank) 800 Bbl mud system

Generator House: 10' x 51' utility house w/ parts storage room, change room w/ lockers, electric distribution center w/ (1) 30hp Sullivan Palatek air compressor, (2) 350KW gen. set p/b Detroit Diesel 60 series

Fuel Tank: (10,500 gal.)

Water Tank: (21,000 gal.)

Dog House: 50'L x 10'W x 8'H

Drill Pipe: 4 1/2" XO

Drill Collars: (19) 6" (2) 8"

House Trailer: Toolpusher's quarters, skidded



(Footprint is on page 23)

Rig 20

RINGO
DRILLING I, L.P.

Drawworks: North Texas U-15 single drum mechanical, 1 1/8" lebus grooving, hydraulic make up & break out catheads, p/b (2) Detroit 60 series rated @ 630hp

Derrick: Upright International 131'

Substructure: Dreco, 9' 10" clear height under rotary beams

Block/Hook: Mud King (250 ton)

Swivel: EMSCO LB-200

Rotary Table: Gardner Denver 17 1/2" square drive w/ split master bushing

BOP: Shaffer LWS 13 3/8" 3000# Double Ram w/ 4 1/2" pipe and blind rams

Closing Unit: Koomey 3 station, 120 gallon

Mud Pump #1: RS F-1000hp triplex, p/b Detroit 16-V-2000 rated @ 1050hp

Mud Pump #2: EMSCO D-500 duplex p/b CAT D-3412

Steel Pits: (2 tank) 800 Bbl mud system

Generator House: 10' x 51' utility house w/ parts storage room, change room w/ lockers, electric distribution center w/ (1) 30hp Curtis air compressor, (2) 360KW gen. set p/b Detroit Diesel 60 series

Fuel Tank: (10,500 gal.)

Water Tank: (6,000 gal.)

Dog House: 50'L x 10'W x 8'H

Drill Pipe: 4 1/2" XO

Drill Collars: (20) 6" (2) 8'

House Trailer: Toolpusher's quarters, skidded



(Footprint is on page 23)

Rig 21

RINGO
DRILLING I, L.P.

Drawworks: Ideco 750, Single Drum, Make-up & Breakout Catheads, Parkersburg SR-22 Hydromatic Brake, p/b (2) Detroit 12V diesel w/ Allison TC-955 Torque Converters rated @ 450hp

Derrick: Lee C. Moore 131' Cantilever

Substructure: 16'H x 26'W x 45'L Box-on-Box w/ Rotary Beams

Block/Hook: Block (250 ton), w/ BJ 4200 Hook

Swivel: (225 ton)

Rotary Table: National/Ideal 27 1/2"

BOP: Shaffer 11" 5000# Double Gate, and Hydril 11" 5000# annular

Closing Unit: Cameron 4 station

Mud Pump #1: F.E.S. MZ-9 p/b CAT 398

Mud Pump #2: F.E.S. MZ-9 p/b CAT 398

Steel Pits: (3) 400 Bbl, 3-Tank Mud System w/ (1) Shale & (2) Suction Tanks

Generator House: 38'L Round Top Utility House w/ Crimped Sides, 42'L, (400KW) Volvo-Penta Generator, (300KW) CAT SR4 p/b CAT D-353, Sullivan Palatek 30DGE-TE Air Compressor

Fuel Tank: (6000 gal.) 6'6" Dia. X 30'L

Water Tank: (21,000 gal.)

Dog House: 7' x 20' Round Top

Drill Pipe: 4 1/2" XO

Drill Collars: (23) 6" (2) 8" (1) BH

House Trailer: Toolpusher's quarters, skidded

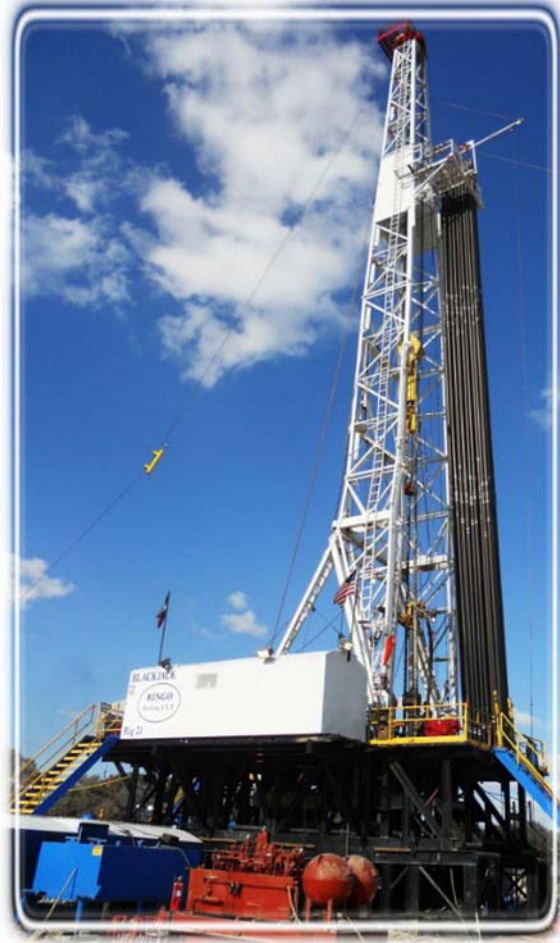

(Footprint is on page 23)

Rig 22

RINGO
DRILLING I, L.P.

Drawworks: OIME SL-7 (split level), mechanical drawworks rated 1000 hp with inline compound, Allison transmissions, powered by two (2) Caterpillar C-15 engines, each rated for 500 hp @ 1800 rpm

Derrick/Substructure: Split level (SL-5) self-elevating BHL (Parco style) substructure 18'H, 131' high x 18.6' base mast

Block/Hook: (350 ton) Continental-Emsco Model RA-44-5 traveling block unitized with a BJ Model 5350 hook.

Swivel: (350 ton) Sentry Model SL315

Rotary Table: Sentry Model SRE275 27 1/2"

BOP: 13 5/8" x 5,000 psi spherical style annular, 13 5/8" x 5,000 psi double ram, 3 1/8" x 5,000 psi choke manifold

Closing Unit: BOPC Model MA130, 210 gallon, five station, with one (1) electric powered triplex pump, two (2) air motor driven pumps, regulating valves, five station remote control panel.

Mud Pumps: (2) Weatherford Model 1300, triplex pumps (mfg in China), rated for 1100hp @ 1200rpm, p/b CAT D-399

Steel Pits: Tri-Flow 1000 bbl 2-pit system. Mud mixing is provided by two (2) 6 x 8 centrifugal pumps, each driven by one 100 hp motor. Five (5) 10 hp and one (1) 7.5 hp mud agitators.

Solids Control: Tri-Flow Model 148 LMSS linear motion shale shaker, Tri-Flow Model 1000 two (2) cone horizontal desander, Tri-Flow sixteen (16) cone desilter.



Generator House: Two (2) CAT 3412 engines with CAT SR-4 generators, each rated at 545 kw prime and 600 kw standby, complete with generator house.

Water Tank: (500 Bbl.)

Dog House: Top doghouse, bottom crew change/parts house

Drill Pipe: 4 1/2" 16.60# Grade G-105 drill pipe

Drill Collars: (25) 6" (3) 8" (1) BH

House Trailer: 2004 Prowler travel trailer 30'

(Footprint is on page 23)

Rig Footprints

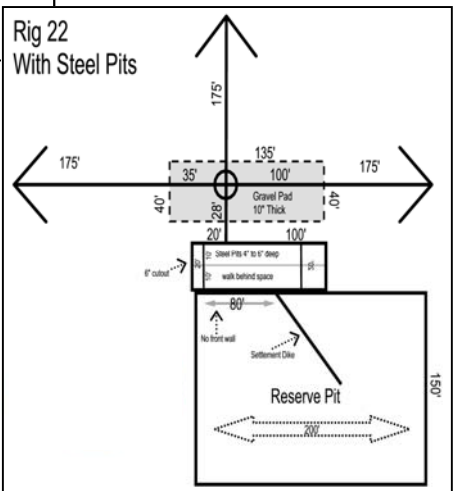
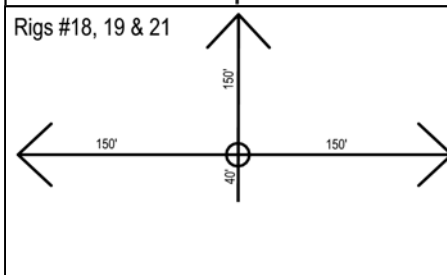
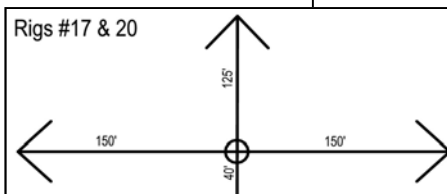
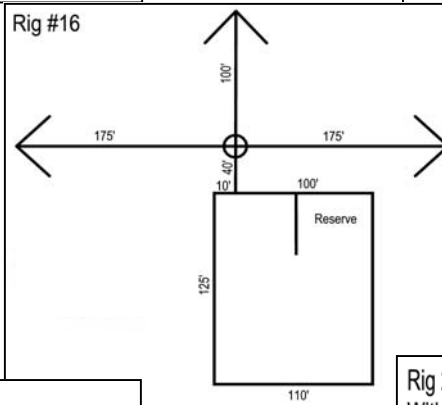
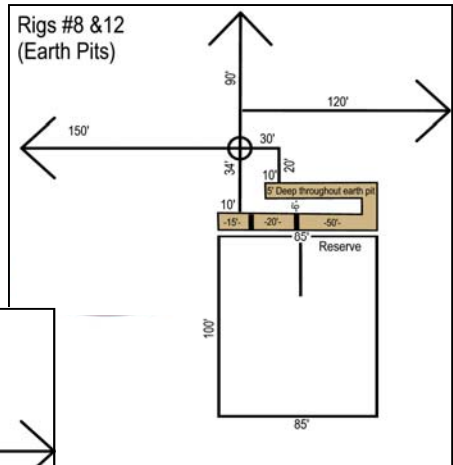
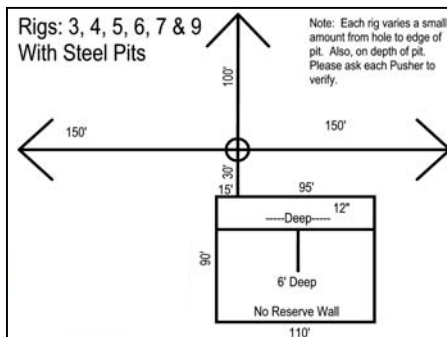
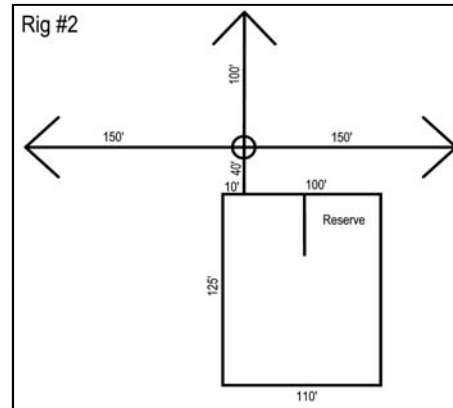
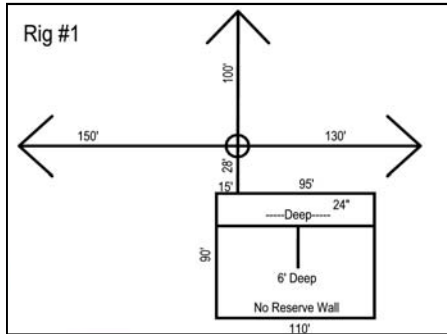



Ringo Trucking, LLC

Ringo's truck fleet consists of twenty trucks with the capabilities of four moves per day. Along with the yard in Tye, Ringo Trucking added a yard in San Angelo in 2010





RINGO

DRILLING I, L.P.



104 Spinks Road, Tye, Texas 79563 ☎ (325) 695-5600 ☎ Fax (325) 695-5639
WWW.RINGODRILLING.COM